



EJB-W. Enclosure with display window

Protection mode:

Type of protection: II 2 GD EEx d IIB / EEx d [ia] IIB
 Class of temperature: T6-T5-T4-T3
 Protection degree: IP66
 Ambient Temp : -20 à +60°C
 Zones : 1-21-2-22

Description:

The EJB enclosures with a display window are rectangular shaped and have the cover with flat joint which is fixed by hexagonal head screws. Standard powder epoxy painting, like RAL 7005.

To contain terminals, contactors, switches, transformers, capacitors, PLC and other electric, electronic equipment and I.S. devices



Technicals data:

Materials:

Body and cover: aluminium alloy.
 Screws: stainless steel.
 Silicone grease IP 65.

On request:

IP 67 protection with o-ring.
 Galvanized steel or stainless steel hinges.
 Galvanized steel equipment plate.
 Push buttons, pilot light, selector switches.
 Breathing / draining valve.
 Other epoxy painting colours different by the standards. Inhibiting treatment for salt mist.

Technical drawing:

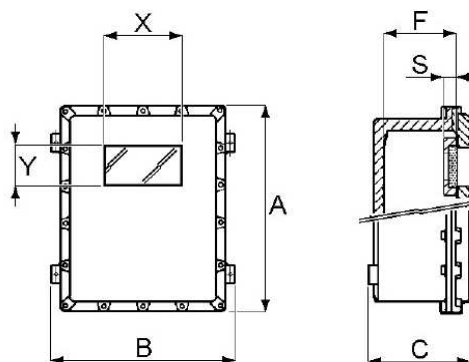

Dimensions table:

Vitre	Type regard									
	W0	W1	W2	W2A	W3	W3A	W4	W5	W6	W7
X	75	105	150	180	210	200	300	300	300	120
Y	75	75	105	40	150	200	50	210	80	108
S*	22	22	27	22	31	36	31	36	22	35

*Pour trouver la profondeur utile des coffrets, il faut soustraire l'espace « S » de « F » indiqué sur le dessin EJB (A1)



EJB-W. Enclosure with display window

Vitre	Type regard					
	WG S	WG 00	WG 0	WG 1	WG 2/3	WG 3L
ø	50	63	79	121	160	260

Type	Windows (Horizontal - Vertical)									
	W0	W1	W2	W2A	W3	W3A	W4	W5	W6	W7
EJB0										
EJB1										
EJB2A	H-V									
EJB4A	H-V	V								
EJB6A	H-V	V								
EJB8A	H-V	H-V	V							H-V
EJB8B	H-V	H-V	V							H-V
EJB9A	H-V	V								
EJB10A	H-V	H-V	H-V	V	V					H-V
EJB10B	H-V	H-V	H-V	V	V					H-V
EJB11	H-V	H-V	H-V	H-V	H-V	H-V	V	V	V	H-V
EJB11A	H-V	H-V	H-V	H-V	H-V	H-V	V	V	V	H-V
EJB11B	H-V	H-V	H-V	H-V	H-V	H-V	V	V	V	H-V
EJB13A	H-V	H-V	V				V		V	H-V
EJB14A	H-V	H-V	H-V	V			V		V	H-V
EJB15A	H-V	H-V	H-V	H-V	H-V	H-V	V	V	V	H-V
EJB17A	H-V	H-V	H-V	H-V	H-V	H-V	H-V	H-V	H-V	H-V
EJB17Q	H-V	H-V	H-V	H-V	H-V	H-V	H-V	H-V	H-V	H-V
EJB18A	H-V	H-V	H-V	H-V	H-V	H-V	H-V	H-V	H-V	H-V
EJB18B	H-V	H-V	H-V	H-V	H-V	H-V	H-V	H-V	H-V	H-V
EJB20	H-V	H-V	H-V	H-V	H-V	H-V	H-V	H-V	H-V	H-V
EJB20A	H-V	H-V	H-V	H-V	H-V	H-V	H-V	H-V	H-V	H-V